



GALLERIA
SOSPENSIONE

1958 / 2026





© Archivio Storico Gardella

Galleria Sospensione

4-arms

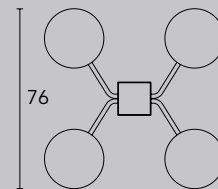
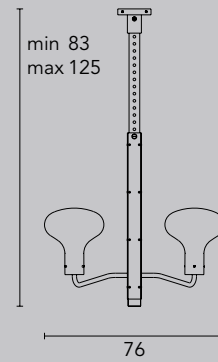

8-arms

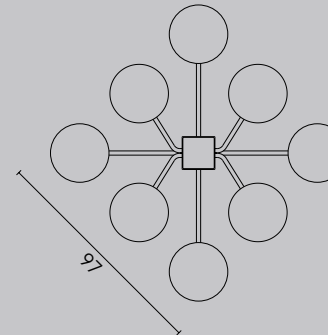
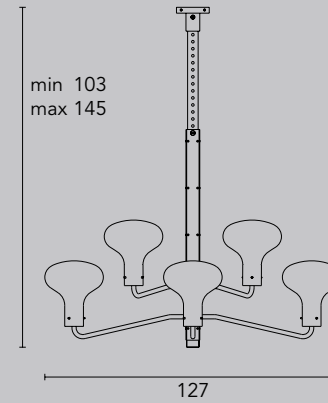

12-arms

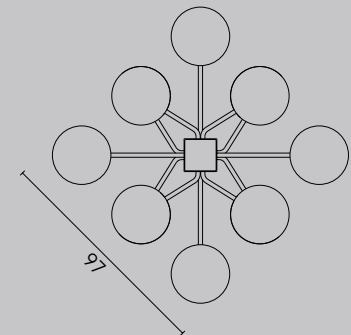
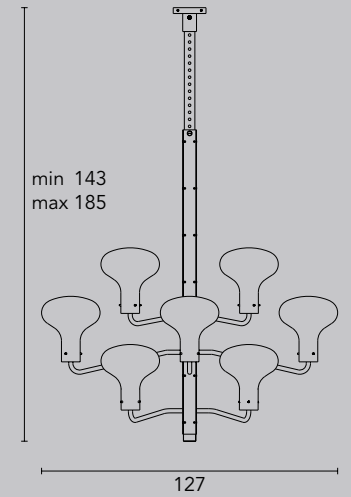

Details

Type: ceiling lamp
 Materials: brass / steel / aluminum / glass
 Weight: 16 / 20 / 25 kg
 Insulation: class I / IP20
 Bulbs: 1xLED E27/E26 806lm (each arm)



Brass



Manganese



White glass



"Non è che io avessi in mente di modificare la società facendo mobili, però io credo che il fatto di scegliere una forma è un po' come scegliere un costume di vita."

"It's not that I had in mind to change society by making furniture, but I believe that choosing a form is somewhat like choosing a mode of life."

Ignazio Gardella

Ignazio Gardella (Milano, 1905 - Oleggio, 1999) was one of the leading figures in Italian 20th century architecture. Even before the war he had performed a series of jobs for the upper classes of Piedmont and Lombardy, clients whom he was able to interpret in many important projects in the period of Reconstruction when he was at the forefront in proposing a new idea of architecture.

Until the 1990s, Gardella would continue designing furniture and accessories, as well as carrying on his extraordinary activity as architect.